



مجری و مشاور، تجهیز و طراحی دکوراسیون، مبلمان،
تجهیزات صوتی و تصویری سالن های کنفرانس، همایش و سینما

CONTRACTOR AND CONSULTANT INTERIOR DESIGN, DECORATIONS AND FURNITURE

AUDIO AND IMAGE EQUIPMENTS FOR AMPHITHEATER, CONFERENCE HALL AND CINEMA



دفتر مرکزی | البرز، کرج، خیابان شهید بهشتی،
پوشه ۱۰۱ | تلفن | ۰۲۶۳۴۲۹۳۳۰۵ - ۰۲۶۳۴۲۹۳۳۰۸
تلفن | ۰۲۶۳۴۲۹۳۳۰۸ | فکس | ۰۲۶۳۴۲۹۳۳۰۸
واتساپ | ۰۲۶۳۴۲۹۳۳۰۸ | تلگرام | ۰۲۶۳۴۲۹۳۳۰۸

NORSA-CO-IR
Office tel | 02634293305 | 34296229
Office fax | 02634293308
Whatsapp | 09355100033
Telegram | 09355100033
Instagram | Norsa_company
Email | Info@norsa-co.ir



آنچه ما هستیم...

WHAT WE ARE...

Norsaco.Tajhizgaran asr-e-Jadid has been established with the aim of providing specialized consulting, design and implementation of acoustic interior architecture and equipping conference halls, conferences, amphitheatres and cinemas

To attain to this goal, these is a necessity of using professional specialists and experts, establishing research and development unit, using the world's latest technology and equipments in Acoustic and Electro-acoustic, improving the ability of production and also the quality of the decorative products, and eventually delivery of the project according to the standards and customer satisfaction. The technical knowledge and quality control of the consultants and experts of this company in its various units such as business, designing, technical and executive, finance and even the professional and artful hands of the experts, results into the creation of attractive places which conform to the latest standards

This company has tried to decrease the time of implementation and eventually the expenditures of the projects by using today's science of managing projects and its powerful executive ability by observing the executive problems

Considering the impossibility of enhancing the quality of any product without obtaining the satisfaction of the customer, the After-Sales unit despite guaranteeing all the products and equipments used in the projects, by preserving continuous contact with the customer and submitting solutions for proper exploitation from the halls, has submitted guarantee of the projects to the customer in order the exploitation from the finished projects will not confront with stoppage due to the repairing problems

All the efforts of your colleagues in this company, is being able to be a sample of using the latest technology, enhancing the quality, observing the worlds latest standards which will result to the confidence of the consultants and the respectful employers by using the above possibilities.

WE HOPE TO HAVE THE CHANCE TO ASSIST YOU

شرکت نورسا تجهیزگران عصر جدید با هدف مشاوره تخصصی، طراحی و اجرای معماری داخلی آکوستیکی و تجهیز سالن های کنفرانس، همایش، آمفی تئاتر و سینما تأسیس یافته است.

نیل به هدف فوق مستلزم بهره مندی از دانش فنی متخصصین و کارشناسان مجرب، ایجاد واحد تحقیق و توسعه، اطلاع و استفاده از دانش و تجهیزات منابع خارجی در زمینه های آکوستیک و الکتروآکوستیک، افزایش توان تولید و بهبود کیفیت قطعات و محصولات دکوراتیو تولیدی و در نهایت تحویل پروژه مطابق شرایط استاندارد و جلب رضایت مشتریان می باشد. دانش فنی و کنترل کیفیت مشاوران و کارشناسان این شرکت در بخش های متعدد بازرگانی، طراحی، دفتر فنی و اجرایی، مالی و ستادی و در نهایت دستان متخصص و هنرمند مجربان به خلق فضایی منجر می شود که با رعایت استاندارد های روز دنیا به زیبایی آراسته گردیده است.

این شرکت افتخار خود می داند که با بهره گیری از دانش های نوین کنترل پروژه و توان بالای اجرایی ضمن رعایت همه مسائل اجرایی سعی بر کاهش زمان اجرا و در نتیجه کاهش هزینه های تمام شده پروژه نماید.

از آنجاییکه ارتقاء کیفیت هیچ محصولی بدون اخذ میزان رضایت مندی مشتریان ممکن نمی شود، واحد خدمات پس از فروش این شرکت با وجود تضمین و گارانتی کلیه محصولات و تجهیزات بکار رفته در پروژه، با حفظ ارتباط مستمر با مشتریان و ارائه راهکارهایی جهت بهره برداری مناسب از سالن، گارانتی پروژه ای نیز به مشتریان خود عرضه نموده تا بهره برداری از پروژه های اتمام یافته به دلیل مشکلات تعمیراتی با وقفه مواجه نگردد.

تمامی تلاش همکاران شما در این شرکت این است که با استفاده از امکانات فوق بتواند الگوئی جهت استفاده از دانش روز، بالا بردن کیفیت، رعایت استانداردهای روز دنیا و در نهایت آن باعث آسودگی خاطر مشاورین و کارفرمایان محترم باشد.

امید است یاری دهنده دستان پر تلاش شما باشیم.

CERTIFICATES



CITATIONS



تقدیرنامه ها



پروژه ها
PROJECTS



Design: Norsa Atelier
Construction: Norsa Projects Management Unit
Taskmaster: Khavaran Institute of Higher Education
Capacity: 303 Persons
Construction Time: 90 Days

Audio **Video** **Light**
 EV Panasonic LAMPO

طراحی: آتلیه طراحی نورسا
اجرا: مدیریت پروژه های نورسا
کارفرما: موسسه آموزش عالی خاوران
ظرفیت: ۳۰۳ نفر
مدت زمان اجرا: ۹۰ روز
Seat
 N-930
 VIP ROYAL

سالن همایش موسسه آموزش عالی خاوران مشهد
CONFERENCE HALL OF MASHHAD KHAVARAN INSTITUTE OF HIGHER EDUCATION

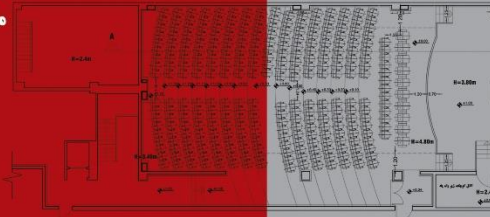

LAYOUT PLAN



طراحی،
 اجرا
 و تجهیز

5



FEATURES
 Capacity: 303 seats
 Area: 385M²

Design,
 Performance
 & equip

NO

6



نورسا

تجهیزات و مدیریت

Design: Norsa Atelier
Construction: Norsa Projects Management Unit
Taskmaster: Islamic Azad University
Capacity: 518 Persons
Construction Time: 150 Days

Audio
EV

Video
SANYO

Light
LightPlanet
Bright technology

طراحی: آتلیه طراحی نورسا
اجرا: مدیریت پروژه های نورسا
کارفرما: دانشگاه آزاد اسلامی
ظرفیت: ۵۱۸ نفر
مدت زمان اجرا: ۱۵۰ روز
Camera
SONY
Seat
N-330
VIP ROYAL CLASSIC

سالن آمفی تئاتر دانشگاه آزاد اسلامی AMPHITHEATER OF ISLAMIC AZAD UNIVERSITY



LAYOUT PLAN

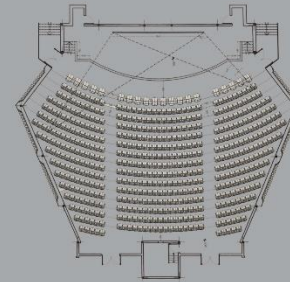

طراحی،
اجرا
و تجهیز

7

FEATURES
Capacity: 518 seats
Area: 900M²

Design,
Performance
& equip

NO

8



نورسا

تجهیزات و اجرا

Design: Norsa Atelier
Construction: Norsa Projects Management Unit
Taskmaster: Fouman Chimie Company
Capacity: 300 Persons
Construction Time: 67 Days

Audio



Video

Panasonic

Light



طراحی: آتلیه طراحی نورسا
اجرا: مدیریت پروژه های نورسا
کارفرما: شرکت فومن شیمی
ظرفیت: ۳۰۰ نفر
مدت زمان اجرا: ۶۷ روز

Camera

SONY

Seat

N 1401
VIP ROYAL

سالن همایش دانشگاه فنی فومن CONFERENCE HALL OF FOUMAN TECHNICAL COLLEGE

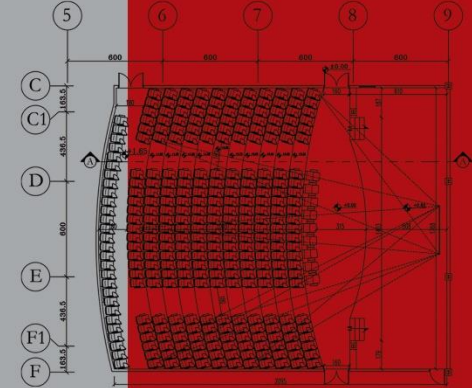

LAYOUT PLAN

طراحی،
اجرا
و تجهیز

9

FEATURES
Capacity: 300seats
Area: 390M²

Design,
Performance
& equip

NO

10

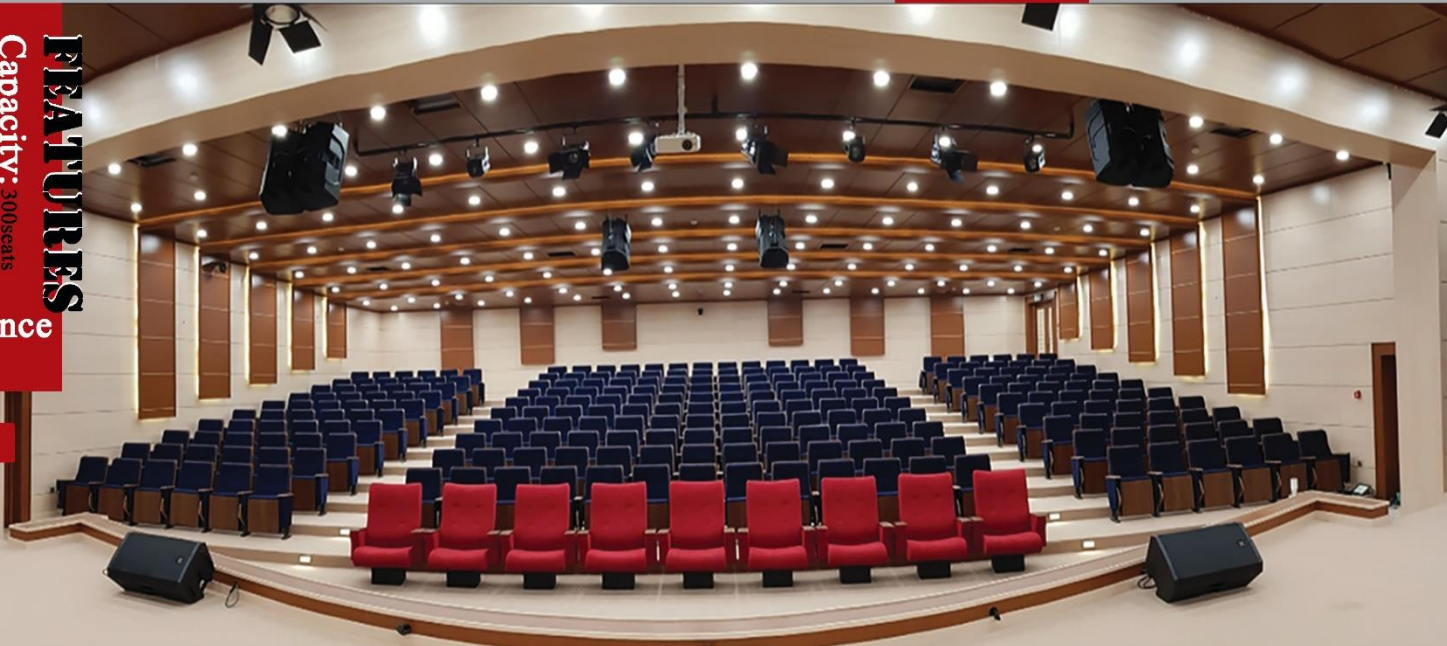

DESIGNS



طراحی و

NO

12

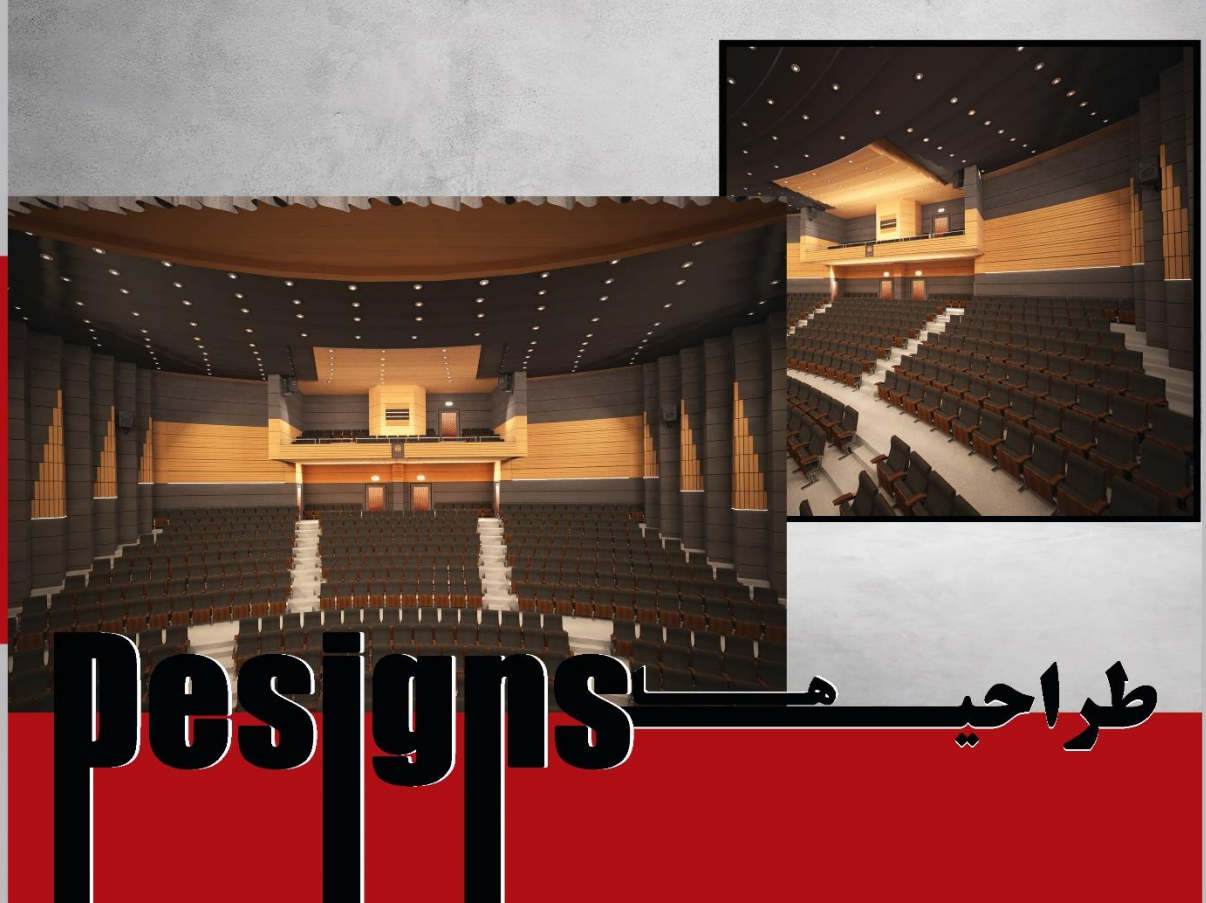



LAYOUT PLAN

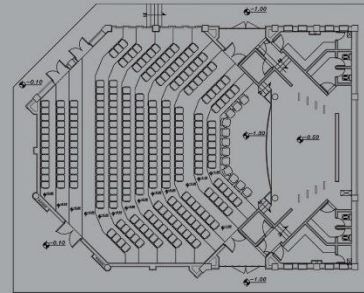

REACTIVUS
Capacity: 269 seats
Area: 385M²

Design,
Performance
& equip

NO

14

طراحی،
اجرا
و تجهیز

13

FEATURES
Capacity: 391 seats
Area: 430M²

Design,
Performance
& equip

NO

16



■ سالن همایش با ظرفیت ۳۹۱ نفر
CONFERENCE HALL WITH THE CAPACITY 391 PEOPLE

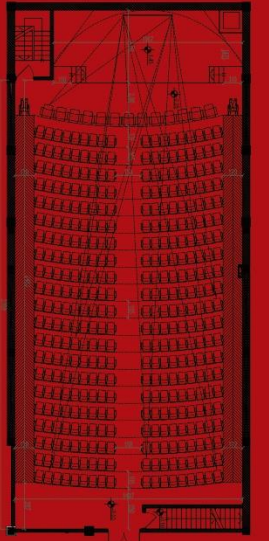

LAYOUT PLAN

طراحی،
اجرا
و تجهیز

15

■ سالن همایش با ظرفیت ۱۹۵ نفر
CONFERENCE HALL WITH THE CAPACITY 195 PEOPLE

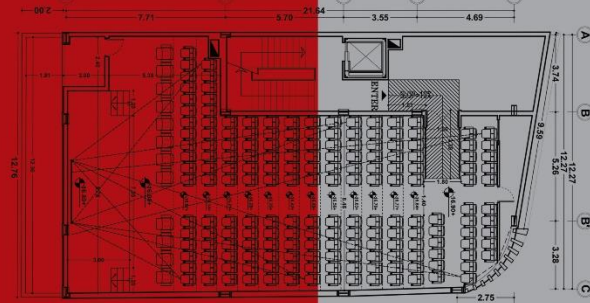

LAYOUT PLAN



FEATURES
Capacity: 195 seats
Area: 205M²
Design, Performance & equip

NO

18

طراحی،
اجرا
و تجهیز

17

■ سالن آمفی تئاتر با ظرفیت ۴۳۰ نفر
AMPHITHEATER WITH THE CAPACITY 430 PEOPLE

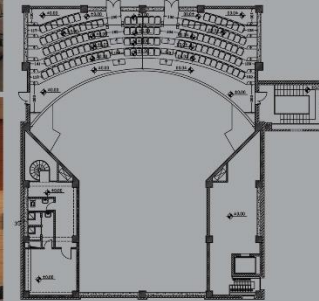
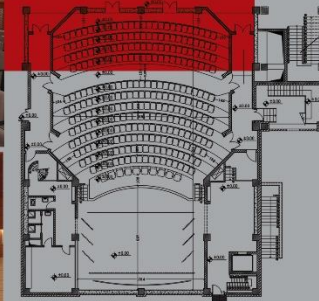

LAYOUT PLAN



طراحی،
 اجرا
 و تجهیز

FEATURES
 Capacity: 430seats
 Area: 540M²

Design,
 Performance
 & equip

NO

20





LAYOUT PLAN

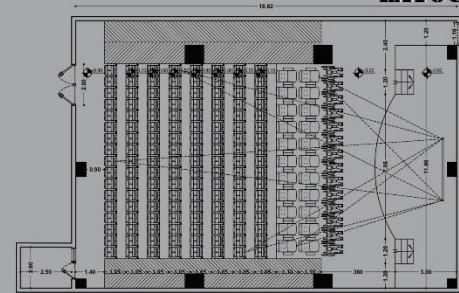

FEATURES
Capacity: 158seats
Area: 250M²

Design,
Performance
& equip

NO

22

طراحی،
اجرا
و تجهیز

21

REAPURUS
Capacity: 473 seats
Area: 500M²

Design,
Performance
& equip

NO

24

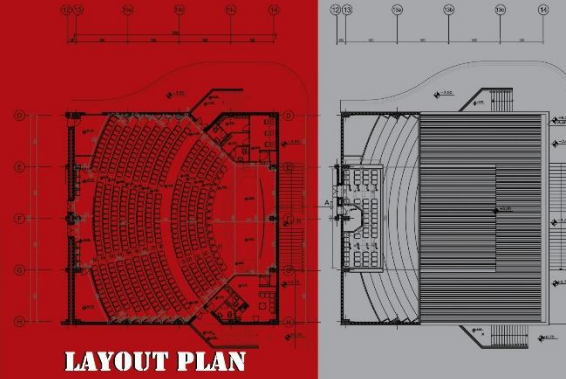

■ سالن همایش با ظرفیت ۴۷۳ نفر
CONFERENCE HALL WITH THE CAPACITY 473 PEOPLE



طراحی،
اجرا
و تجهیز

23

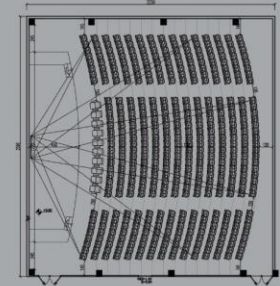

LAYOUT PLAN



FEATURES

Capacity: 474seats
Area: 505M²

Design,
Performance
& equip

NO

26

طراحی،
اجرا
و تجهیز

25

■ سالن جلسات با ظرفیت ۲۳۵ نفر
MEETING ROOM WITH THE CAPACITY 235 PEOPLE

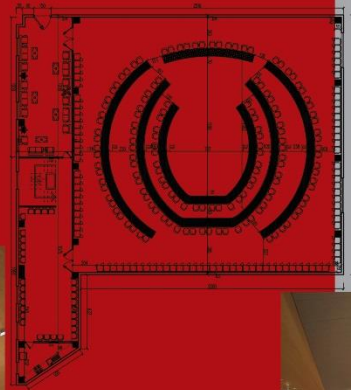

LAYOUT PLAN

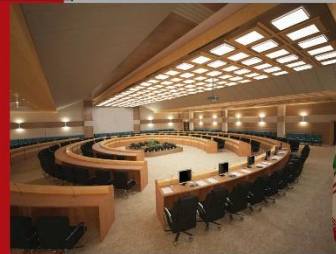

طراحی،
اجرا
و تجهیز

29

FEATURES
Capacity: 235 seats
Area: 505M²

Design,
Performance
& equip

NO

30



FEATURES
Capacity: 38 seats
Area: 52M²

Design,
Performance
& equip

NO

32



سالن جلسات با ظرفیت ۳۸ نفر
MEETING ROOM WITH THE CAPACITY 38 PEOPLE

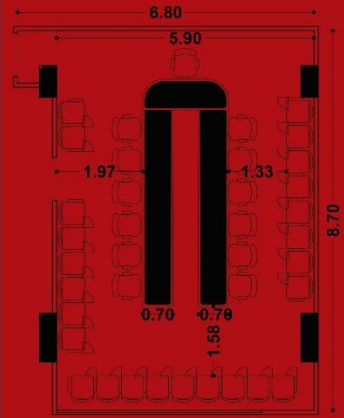

LAYOUT PLAN

طراحی،
اجرا
و تجهیز

31

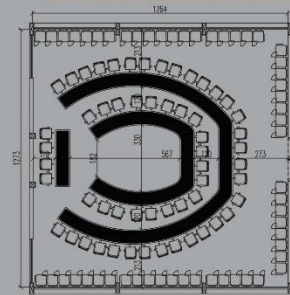

LAYOUT PLAN



REAFURUS
Capacity: 117 seats
Area: 164M²

Design,
Performance
& equip

NO

34

طراحی،
اجرا
و تجهیز

33

FEATURES
Capacity: 8 seats
Area: 24M²

Design,
Performance
& equip

NO

36



■ سینما خانگی با ظرفیت ۸ نفر
HOME THEATER WITH THE CAPACITY 8 PEOPLE

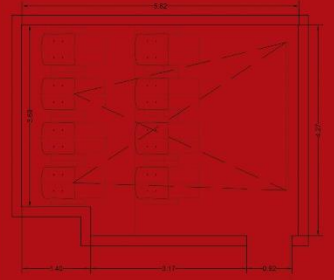

LAYOUT PLAN

طراحی،
اجرا
و تجهیز

35



N-330 Series
First Class

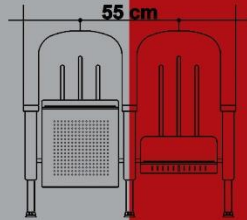

FEATURES
Sites Applicable
Theater and music
Auditorium/Conference
Cinema

NO

38



- | | | |
|---|--|--|
| Can be used in theaters and music halls | | قابلیت استفاده در سالن های تئاتر و موسیقی |
| Can be used in conference and conference hall | | قابلیت استفاده در سالن های همایش و کنفرانس |
| Can be used in cinemas | | قابلیت استفاده در سالن های سینما |
| Ability to add writing-pad | | قابلیت افزودن مسطحه نوشتاری |
| Ability to add cup holder | | قابلیت افزودن مسطحه جا لیوانی |
| Ability to slow burning of fabric and foam | | قابلیت کندسوز نسدن پارچه و فوم |
| Wooden chairs | | سندلی با فرم چسبی |
| Chair with writing-pad | | سندلی با مسطحه تحریر |
| Chair with special writing-pad | | سندلی با مسطحه تحریر ویژه |
| Chair with cup holder | | سندلی با مسطحه جا لیوانی |

SEATS

سندلی

N-730W Series
First Class



FEATURES

Sites Applicable

Theater and music
Auditorium/Conference

FEATURES
Sites Applicable
Theater and music
Auditorium/Conference
Cinema



NO

40

N-730 Series
Economic

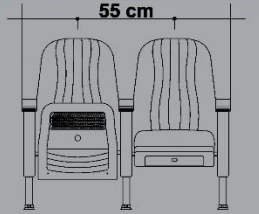

39



N-9306 Series Medium Class

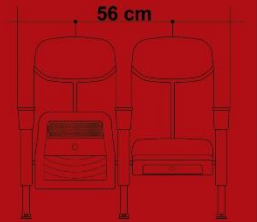

FEATURES

Sites Applicable

Theater and music
Cinema



N-930 Series Medium Class



FEATURES
Sites Applicable
Theater and music
Auditorium/Conference
Cinema

NO

42

41

N-930T Series
Medium Class



FEATURES
Sites Applicable
Auditorium/Conference

N-930T+ Series
Medium Class

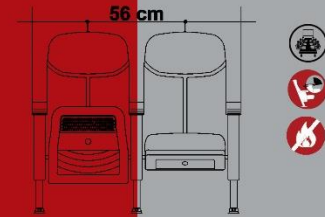

FEATURES
Sites Applicable
Auditorium/Conference



N-1170 Series First Class

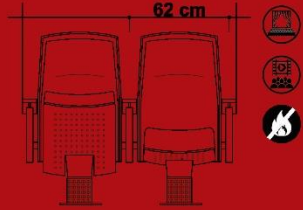

FEATURES

Sites Applicable
Theater and music
Cinema

FEATURES

Sites Applicable
Theater and music
Auditorium/Conference



N-930W Series First Class

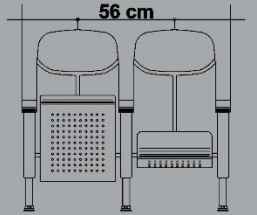

NO

46

45



N-1430T Series First Class

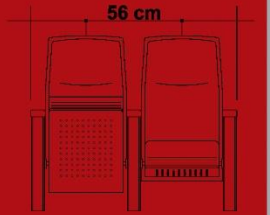

FEATURES

Sites Applicable

Theater and music
Auditorium/Conference



N-1410 Series Medium Class

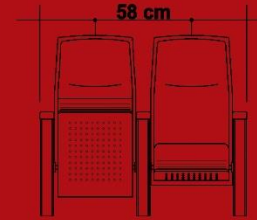

FEATURES
Sites Applicable
Theater and music
Auditorium/Conference

47

NO

48

N-1480 Series
First Class



FEATURES
Sites Applicable
Theater and music
Auditorium/Conference

N-1480+ Series
First Class

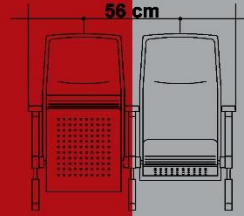

FEATURES
Sites Applicable
Theater and music
Auditorium/Conference

NO

50

49

N-2030 Series
First Class



FEATURES
Sites Applicable
Theater and music
Cinema

FEATURES
Sites Applicable
Cinema



NO

52

N-1790 Series
Medium Class

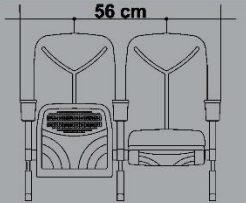

51

FEATURES
Sites Applicable
Theater and music
Cinema



SENATORVIP Series
Vip



SENATOR CLASSIC VIP Series
Vip



FEATURES
Sites Applicable
Theater and music
Cinema

FEATURES
Sites Applicable
Auditorium/Conference



ROYALVIP Series
Vip



ROYAL CLASSIC VIP Series
Vip

FEATURES
Sites Applicable
Auditorium/Conference



515A/515



S218A/S218

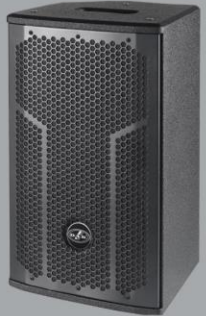

508A/508



512A/512

DAS
AUDIO ACTION



AUDIO SYSTEM سیستم صوتی



HQ-112.43/64/95

HQ SERIES



HQ-212.64/95



HQ-218

500
ACTION SERIES
DAS AUDIO ACTION



M512A/M512



S18



S118A



S25A/S25

**DX SERIES
AMPLIFIERS**

DAS AUDIO AMPLIFIER INTEGRAL



INTEGRAL-A404 POWER 8 OHMS BRIDGED 2*200W



INTEGRAL-A1004 POWER 8 OHMS BRIDGED 2*500W



INTEGRAL-A1604 POWER 8 OHMS BRIDGED 2*800W



INTEGRAL-WA2
POWER 8 OHM, BOTH CHANNELS DRIVEN 4*12.5W



INTEGRAL-A402 POWER 8 OHMS BRIDGED 400W



INTEGRAL-A1002 POWER 8 OHMS BRIDGED 1000W



INTEGRAL-A1602 POWER 8 OHMS BRIDGED 1600W



INTEGRAL-WA2
POWER 8 OHM, BOTH CHANNELS DRIVEN 2*12.5W



DX-80 | POWER 4 OHMS BRIDGED 4000W



DX-100 | POWER 4 OHMS BRIDGED 7000W



DX-80 | POWER 4 OHMS BRIDGED 4000W



DX-100 | POWER 4 OHMS BRIDGED 7000W



DAS
AUDIO CEILING



CL-6 CL-6T



CL-5 CL-5T



CL-8 CL-8T



CL-6-TB

DAS AUDIO CEILING

CEILING SERIES

DAS
AUDIO AMPLIFIER PA



PA-900 POWER8OHMSBRIDGED900W



PA-500 POWER8OHMSBRIDGED500W



PA-2700POWER8OHMSBRIDGED2700W



PA-1500POWER8OHMSBRIDGED1500W



PA-4000POWER8OHMSBRIDGED4250W



DX SERIES
AMPLIFIERS

DAS AUDIO AMPLIFIER PA

ACTION SERIES
PTC330N
AVER IMAGE SYSTEM



PTC330N

Precision Matters

AI Auto Tracking NDI® IIX PTZ Camera

TallyLamp

Front



Back



IR Sensor PowerIndicator

PoE+ DC 12V
RS-232 3G-SDI
RS-422 HDMI
Line in USB 3.0 Type-C

AVER
IMAGE SYSTEM



IMAGE SYSTEM سیستم تصویر

NO

66

SENNHEISER
AND-C1-D1



SENNHEISER
CONFERENCE SYSTEM



سیستم کنفرانس
Conference SYSTEM